

Introduction

AC coupling is common in amplifier circuits for practical and historical reasons. The practical reason is to remove DC power on a transmission line and into a load. The historical reason is to conform to the default standards of tradition.

The historical perspective also reveals the motivation behind typical driver design choices. The initial IC drivers were high-speed amplifiers run with a high-voltage supply, such as 12V. If the output of the amplifier is biased mid-supply for linearity concerns, 6V is delivered to the load. This voltage can be reduced by lowering the supply or adding an AC coupling capacitor.

Modern amplifiers are high-speed amplifiers run with low-voltage supplies. While the lower supply voltage reduces the amount of quiescent power into the load, portable devices still demand the use of AC coupling capacitances to prolong battery life and to isolate ground connections.

To avoid using large output coupling capacitor values, a smaller AC coupling capacitor and bias resistor network is placed at the amplifier's input. This technique requires both positive and negative supplies, while most modern systems no longer have negative supplies.

In systems limited by single-supply operation, other AC coupling techniques and trade-offs must be explored. First, the common way to transmit video signals is presented with the associated design trade-offs. Multiple improvements are then discussed. Next, a SAG feedback network is applied to minimize the output capacitance. The traditional technique can also be improved by the addition of a charge pump. Finally, a DC-Restore circuit is added at the input of the video driver. In this case, two of the three original coupling capacitors are eliminated and the third is drastically reduced.

Since design choices in all four cases are made for similar performance, the circuits can be compared in terms of size of coupling capacitors, power supply noise and board area. A table is provided to facilitate an understanding of the strengths and weaknesses of each improvement.

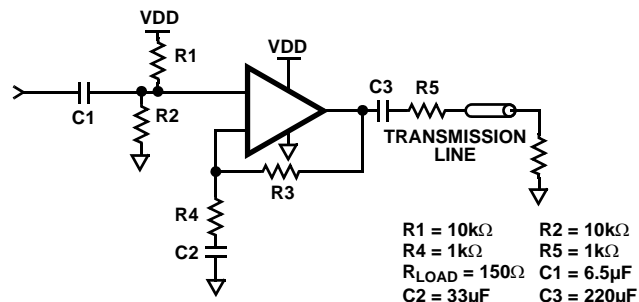

FIGURE 1. TRADITIONAL TECHNIQUE FOR TRANSMITTING VIDEO SIGNALS

Traditional AC Coupling Technique

The traditional technique for transmitting signals with single-supply is shown in Figure 1.

Resistors R_1 and R_2 set the bias voltage at the input of the amplifier, placing it in the linear operating region. The parallel combination of R_1 and R_2 form a low frequency pole with C_1 . The values of R_1 and R_2 are set by the video driver's input bias current. If they are too large, the offset voltage at the input will be unacceptably large as well. Since their sizes are limited, C_1 must be sufficiently sized to guarantee that the input pole is lower than the minimum video signal frequency.

C_2 is required to keep the DC gain at unity. The size of C_2 is determined by R_3 and R_4 values. For a current feedback amplifier, the feedback resistor R_3 is predetermined by the amplifier design. For a voltage feedback amplifier, the feedback resistor value is limited by the interconnecting parasitic capacitance at the inverting input of the amplifier. A large feedback resistor and excessive parasitic capacitance will lead to instability problems. The parasitic capacitance can be minimized to approximately 3pF with short traces and good layout.

C_3 is needed to avoid putting unnecessary DC bias voltage into the load. The size of this capacitor is determined by the line impedance (typically 75Ω) and the minimum signal frequency.

These three poles occur in close proximity so their effect is additive. Therefore, all three poles must be placed well below the desired cut-off frequency. For the example of a video system, the lowest frequency of interest is the vertical sync at 60Hz.

The effects of pole placement on the low-side cut-off frequency of a video driver system are shown in Figure 2. The curves are displayed for the circuit in Figure 1 with two values of C_1 , 0.1 μF and 6.5 μF . With the 0.1 μF capacitor, the pole appears at 318Hz and a 60Hz signal is attenuated by 11dB. With a 6.5 μF capacitor, the pole is lowered to 6Hz, allowing a 60Hz signal to pass with less than 1dB of attenuation.

The effect in the time domain (Figure 3) is drastic. The input to the video driver is plotted in yellow. The output with $C_1 = 6.5\mu\text{F}$, a respectable duplicate, is plotted in pink. Finally, the output with $C_1 = 0.1\mu\text{F}$ is plotted in blue. The capacitance is small enough that the voltage drifts up during the sync pulse, throwing off the average value once the video information returns. This offset corrupts the intensity information of the video signal.

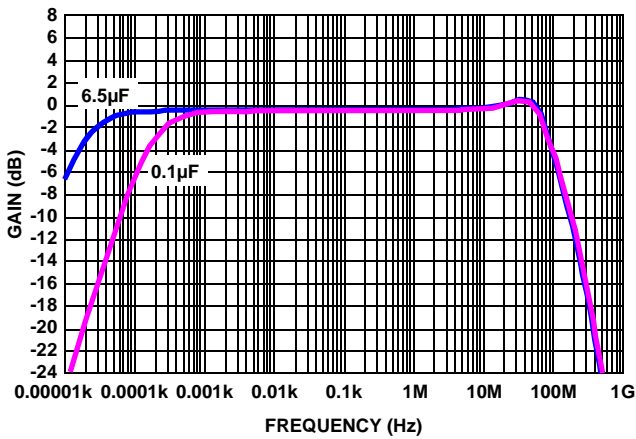

FIGURE 2. BANDWIDTH WITH $C_1 = 0.1\mu\text{F}$ AND $C_1 = 6.5\mu\text{F}$ (MARK 60Hz)

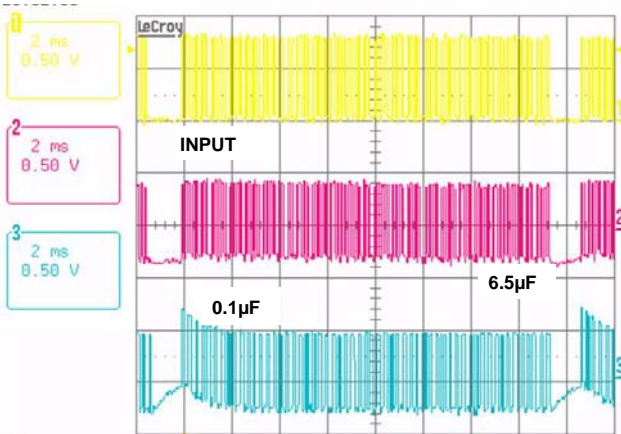

FIGURE 3. TIME DOMAIN INPUT AND OUTPUT OF VIDEO DRIVER WITH $C_1 = 0.1\mu\text{F}$ AND $C_1 = 6.5\mu\text{F}$

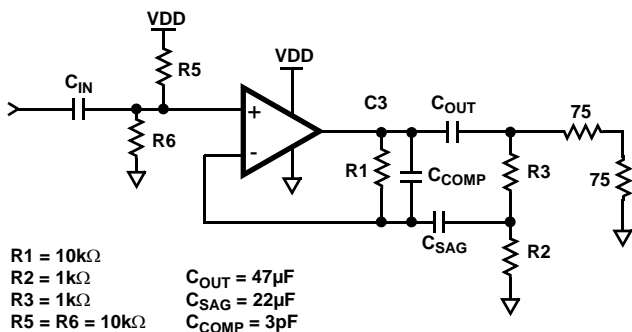

FIGURE 4. ADJUSTED VIDEO DRIVER CIRCUIT WITH FEEDBACK TO REDUCE OUTPUT CAPACITANCE

Thus far, we have argued that larger capacitance is better for video systems since it reduces the low frequency pole and preserves the low frequency contents of the video signal. How large is reasonable? Size and cost provide an upper bound for capacitance value at $220\mu\text{F}$.

Reducing the Output Capacitance (C_3) with Feedback

In many cases, $220\mu\text{F}$ is physically too large to be included on a board. A feedback network can be added to create an effectively large output coupling capacitance (Figure 4). The primary trade-off with this set-up is capacitive size vs load on the driver. Simplistically, if the capacitor is 3x smaller, the driver must drive 3x harder to deliver the same signal to the load. The additional output swing may suffer from issues of linearity.

The area consumed by this feedback network is relatively small, despite the number of components. R_1 , R_2 , and R_3 can be very small and placed close to the inverting input. The size and proximity reduces the parasitic capacitance.

A plot of the gain vs frequency for C_{SAG} (the feedback capacitance) varied from $1\mu\text{F}$ to $220\mu\text{F}$ and is shown in Figure 5. The lower cut-off is extended through peaking. When the feedback capacitance is $1\mu\text{F}$, that extension is not enough to pass the vertical sync information. For all plotted values greater than $1\mu\text{F}$, the lower cut-off is sufficient. Larger values can be used, but will effect settling time.

The most appealing aspect of the circuit in Figure 4 is the dual function of C_{SAG} . In this configuration, C_2 is not needed. C_{SAG} provides the feedback to scale the output capacitance, as well as the unity-gain DC characteristic formerly provided by C_2 . C_{COMP} is added instead of C_2 , but since it utilizes the Miller effect, it is three orders of magnitude smaller than the original C_2 .

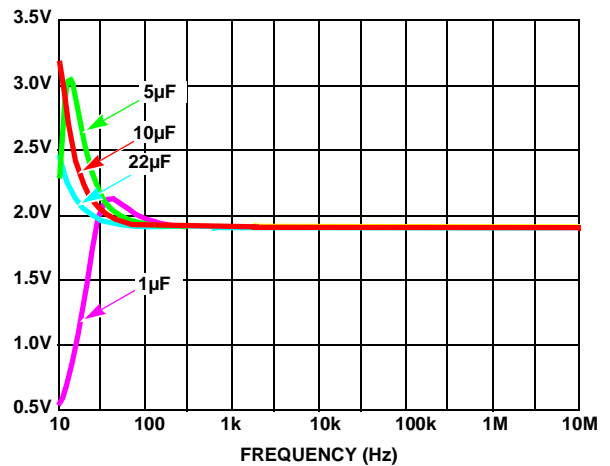

FIGURE 5. GAIN PLOT FOR VIDEO DRIVER WITH FEEDBACK NETWORK WITH VARIOUS C_{SAG}

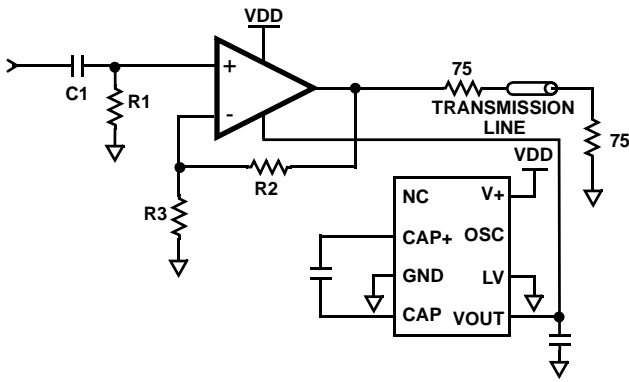

FIGURE 6. VIDEO DRIVER WITH CHARGE PUMP

Creating Dual Supplies with a Charge Pump

One of the primary motivations for including coupling capacitors was the migration of designs from dual supply to single supply. A charge pump is a separate IC that creates a negative supply. Adding a charge pump (Figure 6) allows the designer to eliminate the output capacitance, but with added cost, increased noise, and larger power dissipation. The input coupling capacitance, C_1 , is still needed to remove the DC content of the video signal.

The limitations of this option are dependent on the characteristics of the charge pump. Since a switching circuit is used to create the opposite polarity of voltage, the frequency of this switching will appear as noise on our negative power supply and in our circuit. This conversion is imperfect, so a positive input of 5V can be used to create about -3.5V with a diode-based charge pump. A charge pump with integrated FET switches can create -4.5V.

To reduce area with minimum trade-offs, a video driver with a built-in charge pump, such as the ISL59830, can be chosen. The internal noise has been minimized and the power supply rejection is 40dB. The output exhibits a 10mV_{P-P} signal at 167MHz. With a maximum video frequency of 100MHz, this switching noise is well out of the signal range.

Using a DC-Restore to Reduce Coupling Capacitance

The addition of a DC-Restore circuit can reduce all three of the external AC coupling capacitors in Figure 1. Figure 7 shows the block diagram of a DC-Restore circuit. It consists of 4 simple sections: an input RC network, an op amp configured as a buffer, a FET switch, and a current source. In the absence of an input signal, R_{IN} drains the input node to ground. The op amp loop has negative feedback through the inversion provided by the FET, keeping the non-inverting input equal to the inverting input. The discharge current drains the input capacitance except when the FET switch is turned on. This action eliminates the intensity abnormalities

highlighted in Figure 3. In addition, it drastically reduces the size of the capacitor needed at the input. The value of the pole is no longer subject to the value of bias resistors, but to the output impedance of the current source. Since the output impedance of current source is designed to be large, the value of C_{IN} is smaller than in the traditional technique (where it was called C_1). Because the value of the current source is set by design parameters, C_{IN} must be chosen appropriately. Changing the value of C_{IN} will still cause changes in the input pole as reflected in the time domain plots shown in Figure 2. Again, if the value of C_{IN} is too small, the intensity of the video signal will be compromised (Figure 8). A value of 100nF is large enough to eliminate the offset.

In the traditional video driver circuit, increasing coupling capacitor values improves performance. However, raising the DC-Restore input capacitance above 100nF increases its associated time constant and only adds to the set-up time of the circuit. Recalling the traditional technique of Figure 1 where C_1 is equal to 6.5μF, this method has reduced the input capacitance by a factor of 65.

It is noteworthy that an IC has been added to achieve this reduction in input capacitor size. The additional board area is justified when considering the effect on the other two coupling capacitors. The complete video driver with DC-Restore is shown in Figure 9.

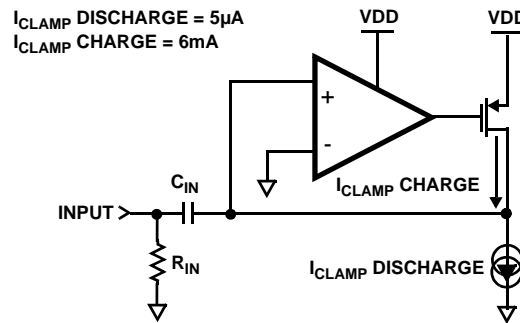

FIGURE 7. BLOCK DIAGRAM OF DC-RESTORE CIRCUITRY

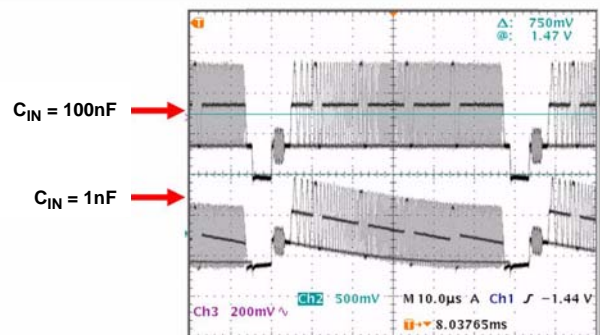

FIGURE 8. VIDEO SIGNAL THROUGH DC-RESTORE CIRCUIT WITH $C_{IN} = 100nF$ AND $C_{IN} = 1nF$

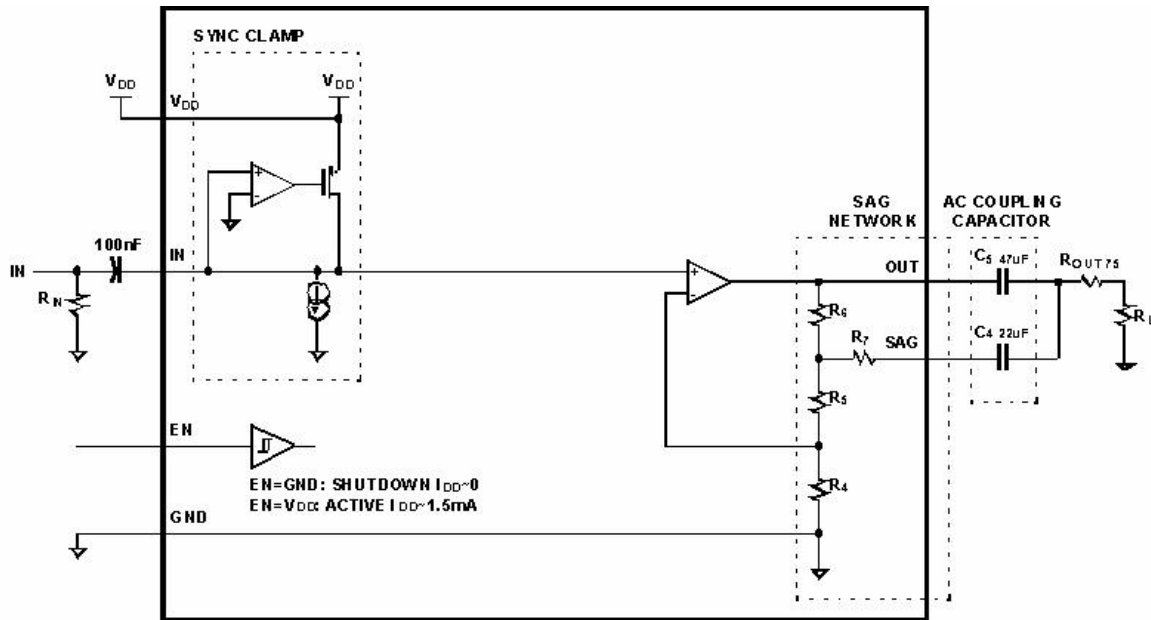

FIGURE 9. VIDEO DRIVER WITH BUILT-IN DC-RESTORE

The output AC coupling capacitance, C_3 , is reduced through a SAG feedback network. With an integrated feedback network, there are no PCB parasitics to be compensated, so no compensation capacitance is needed.

Notice that there is no capacitor from the inverting node of the video driver to ground (C_2 in Figure 1). The output and both inputs of the video driver are biased at ground through the discharge current source and the feedback resistors of the video driver. C_2 is no longer needed since the non-inverting node (and through negative feedback, the inverting node) is now biased at ground instead of mid-supply.

Comparison of AC Coupling Techniques

The critical issues are presented in Table 1. As expected, the traditional video driver technique has the largest coupling capacitors and therefore the largest amount of printed circuit board (PCB) area. The SAG feedback network can be configured to remove C_2 and reduce the output capacitance by a factor of 4. The use of a charge pump removes C_2 and C_3 , resulting in a substantial decrease in board size. However, the switching of the charge pump makes the power supplies noisy. Finally, consider the video driver circuit with a DC-Restore on the input. This solution reduces all three of the coupling capacitors and minimizes the board area. This accomplishment adds no noise to the power supply and does not degrade the performance of the system.

Conclusion

Many types of video driver circuits have been discussed. If the traditional technique must be adapted to minimize board space, there are three options available. First, a SAG feedback network can be used to reduce the output coupling capacitance. Secondly, a charge pump can be added to create a negative supply. Lastly, a DC-Restore network can be configured at the input of the video driver to set the bias conditions of the op amp. This substitution allows for the reduction or elimination of all of the large AC coupling capacitors typically used in video drivers.

TABLE 1. TRADE-OFFS OF VARIOUS TECHNIQUES USED TO MINIMIZE AC COUPLING CAPACITANCE IN VIDEO DRIVERS

TECHNIQUE	C_{IN} (C_1)	C_{GAIN} (C_2)	C_{OUT} (C_3)	SUPPLY NOISE	PCB AREA
Traditional EL5360	6.5 μ F	33 μ F	220 μ F	Low	Largest
SAG Compensation EL8300	6.5 μ F	None	47 μ F	Low	Large
Charge Pump ISL59830	6.5 μ F	None	None	High	Small (Internal CP)
DC-Restore ISL59110	0.1 μ F	None	47 μ F	Low	Small

Intersil Corporation reserves the right to make changes in circuit design, software and/or specifications at any time without notice. Accordingly, the reader is cautioned to verify that the Application Note or Technical Brief is current before proceeding.